

SIMULATION OF INTERRELATIONS OF THE EVERGLADES' MARSH, PEAT, FIRE, WATER AND PHOSPHORUS *

SUZANNE BAYLEY and HOWARD T. ODUM

Department of Environmental Engineering Sciences, University of Florida, Gainesville, Fla. 32611 (U.S.A.)

(Received August 29th, 1975)

ABSTRACT

Bayley, S. and Odum, H.T., 1976. Simulation of interrelations of the Everglades' marsh, peat, fire, water and phosphorus. *Ecol. Modelling*, 2: 169—188.

Some of the principal controlling factors affecting the Everglades marsh system were combined in a simple model including growth of grass, water levels, rain, transpiration, peat deposition, fire and phosphorus and controlled inflow of water containing nutrients. Using data from published sources, coefficients were estimated and the model was simulated for several regimes, for varying concentrations of nutrient in the inflows and for varying access to fire. The resulting graphs resemble patterns reported from the Everglades, with some regimes producing regular repeating patterns and frequent small fires, whereas other regimes produced erratic and widely fluctuating patterns of vegetation, flood and fire. High phosphorus increased water loss by affecting plant transpiration: oscillations of vegetation and fire caused nutrient oscillations. Inflow of low nutrient water decreased nutrient levels by binding nutrients in plant masses. Continuous high water levels developed large accumulations of vegetation and peat, binding the nutrients, making larger fires when water levels were lowered. If this model is pertinent, a regular period of variation of water inflow and limited nutrients may be means for management of marshes for long range stability.

INTRODUCTION

Freshwater marshlands in many sub-tropical areas grow in erratic regimes of rainfall, hydroperiod, peat formation, and fire. Efforts by man to manage these lands as in south Florida have produced major changes, sometimes with unexpected displacements of vegetation type. To help understand the factors involved in marshlands and the effects of managements prospectives, we sup-

* Work under contract #14-10-9-900-363 between the National Park Service, U.S. Department of the Interior, and the University of Florida. Simulation was supported by the Division of Biology and Medicine of the U.S. Atomic Energy Commission, under contract AT-4-1-4150. Analog programming was aided by Larry Burns and Thomas Bullock using facilities of Nuclear Engineering Sciences.

ply here the results of computer simulations that relate several of the major aspects: biomass, water level, nutrient, peat accumulation, and fire. Specifically considered is the Everglades' marsh of south Florida where dikes, channels and water conservation areas have changed water regimes and developed controversy in recent years.

The Florida Everglades comprise a low, flat basin in south Florida characterized by alternating wet and dry seasons, sawgrass (*Cladium jamaicense*) as the predominant vegetation type, and large deposits of organic soil. The Everglades' basin, 100 miles long and 40 miles wide, extends from the edge of Lake Okeechobee south and southeast in the Everglades National Park with a total change of elevation of only 20 feet between Lake Okeechobee and Florida Bay. Much of this basin is limestone or marl of Pliocene origin (Davis, 1946), covered in part with peat. Carbon fourteen dating indicates that the oldest deposits are only 5,000 years old (Stephens, 1956).

The vegetation of this vast freshwater marsh has been described by numerous authors, the best known discussions being that of Davis (1943) and Loveless (1959). The main subsystems present are the sawgrass ecosystem, the tree islands, the aquatic slough ecosystems and the wet prairies. The salt marsh and mangrove ecosystems are not located in the Everglades as they are usually defined.

Sawgrass communities make up approximately 65–70% of the total Everglades (Loveless, 1959) but less than 10% of the Everglades National Park. In the northern and central part of the Everglades the sawgrass associations cover vast areas and provide tall dense ground cover. Toward the south the stands become less extensive, and the plants are short and sparse. There are three generalized types of sawgrass associations, the dense sawgrass type, the sawgrass maidencane (*Panicum hemitomon* Schult) association and sawgrass associated with myrtle (*Myrica cerifera* L.) and holly (*Ilex cassine* L.). The change from the pure sawgrass community to the last two communities occurred to a great extent during the 1940's as a consequence of altered hydroperiod and fire. In most areas of the Everglades the length of the hydroperiod and depth of the water control the growth of the sawgrass marshes as well as that of all the other ecosystems. The hydroperiod is defined as that time duration that water is present in the upper soil layers. Sawgrass responds optimally to long hydroperiods.

The hydroperiod for the entire area is controlled by the runoff from Lake Okeechobee, rainfall and rate of release of absorbed water by the peat deposits. The average rainfall is approximately 55–65 inches/year with 70% of it falling in the period from June to November. Due to their large water holding capacity, the peat deposits extend the length of the hydroperiod in most areas. Areas which lack peat experience a shorter hydroperiod and increased environmental stress due to large short term fluctuations in temperature and water availability.

The drainage of the Everglades for agriculture started at the beginning of the century. Since 1922–1924 Lake Okeechobee waters have not drained in-

to the Everglades except in times of flood (Tabb, 1963). In the late 1940's levees were completed around Lake Okeechobee controlling even the floods. The marsh communities may have responded to the drier conditions by producing increased amounts of woody material. In the early 1950's large areas of land not in agricultural use were designated as water conservation areas. These were intended as an additional flood control measure and to supply the Biscayne aquifer. The plant populations in these areas have adapted to wetter conditions, with many sawgrass associations being replaced by aquatic communities. Further south in the park, the vegetation changes are continuing with sawgrass increasingly being replaced by woody and fire tolerant species such as willow, even though water in limited volumes has been channelled to the park in the last 5 years. Thus, man in the last 50 years has obtained complete control of water runoff flows in south Florida. The resulting changes in water drainage patterns, the freshwater aquifer levels, the rate of oxidation of soil and alterations in animal communities have been profound.

The net effect of these manipulations on the interacting south Florida ecosystems is still awaiting detailed exploration. Modeling and simulation could help predict some of the possible outcomes of present management policies. What effects do the controllable parameters have on the system? What pattern of water and nutrient supply produce the most stable regime in the long run? In this paper several of the factors important to marshes are included in a model which is simulated to show possible interactions that may be occurring in the more complex real systems, especially those of Florida.

THE MODEL

Part of the natural processes described above can be expressed in an energy circuit diagram (Fig. 1). The diagram represents mathematical rate of change equations which link the interacting segments of an ecosystem. The important variables included in the model of the sawgrass system were: the sawgrass population (Q_3), the water on the surface and in the soil (Q_1), the concentration of nutrient limiting factor (Q_2), in this case, phosphorus, and the dead organic material peat (Q_4).

The amount of marsh present at a given time is dependent upon the recent history of the system as well as new photosynthesis building and maintaining structure. Respiration, formation of peat from accumulated organic material and fire act as drains on the storage of sawgrass.

The water level regulates the sawgrass in a dual fashion. In the real system, sawgrass is favored by approximately 1 foot of surface water that is present 9 months of the year. It can tolerate subsurface water for at least 3 months. In addition, the water level usually determines the likelihood of fire. In the model both of these factors are incorporated. The fire switch turns on when water is low and the fire access is high.

The nutrient requirements for plant growth are represented by the phos-

phorus, which becomes a state variable in the model. In the waters over the Everglades phosphorus occurs in low concentrations, <0.02 mg/l (Sullivan et al., 1971), however, other limiting factors, such as molybdenum, may behave similarly. Phosphorus is possibly more important due to the man-induced eutrophication which can be included in the simulation. Important

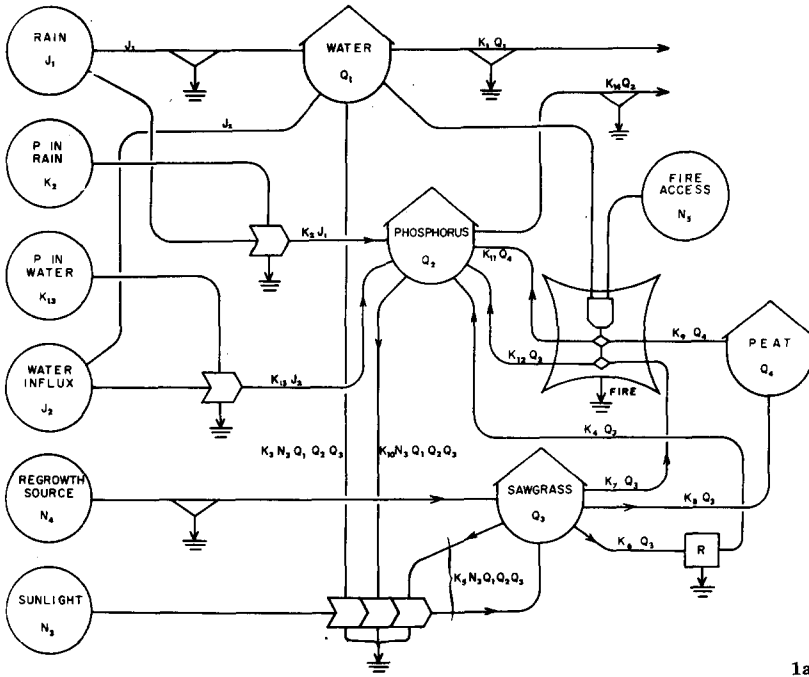

1a

SAWGRASS MARSH MODEL IN EQUATION FORM

WATER $\dot{Q}_1 = J_1 + J_2 - K_3 N_5 Q_1 Q_2 Q_3 - K_1 Q_1$

PHOSPHORUS $\dot{Q}_2 = K_2 J_1 + K_{13} J_2 + \overbrace{K_{11} Q_4 + K_{12} Q_3}^{Q_2 \times 10^6 \text{ WHEN } Q_2 > \text{FULL SCALE}} + K_4 Q_3 - K_{10} N_5 Q_1 Q_2 Q_3 - K_{14} Q_2$

SAWGRASS $\dot{Q}_3 = K_5 N_5 Q_1 Q_2 Q_3 - \overbrace{K_7 Q_3}^{\text{WHEN FIRE IS ON}} - K_8 Q_3 - K_9 Q_3 + K_{15} N_4$

PEAT $\dot{Q}_4 = K_6 Q_3 - \overbrace{K_{16} Q_4}^{\text{WHEN FIRE IS ON}}$

FIRE IS ON WHEN $Q_1 < N_5$

1b

$$\text{WATER} \left[\frac{\dot{Q}_1}{1000} \right] = \left[\frac{J_1}{1000} \right] + \left[\frac{J_2}{1000} \right] - 10 \left(\frac{1.2 \times 10^7 K_5 10}{10} \right) \left[\frac{N_3 Q_1 Q_2 Q_3}{1.2 \times 10^{10}} \right] - 10 \left[\frac{N_3 Q_1 Q_2 Q_3}{1.2 \times 10^{10}} \right] - K_1 \left[\frac{Q_1}{1000} \right]$$

$$\text{PHOSPHORUS} \left[\frac{\dot{Q}_2}{0.03} \right] = 10 \left(\frac{33,333 K_1}{10} \right) \left[\frac{J_1}{1000} \right] + 100 \left(\frac{33,333 K_{10}}{100} \right) \left[\frac{J_2}{1000} \right] + 10 \left(\frac{166,666 K_4}{10} \right) \left[\frac{Q_3}{5000} \right] - 100 \left(\frac{4 \times 10^4 K_{10}}{100} \right) \left[\frac{N_3 Q_1 Q_2 Q_3}{1.2 \times 10^{10}} \right] - 10 \left(\frac{K_4}{10} \right) \left[\frac{Q_2}{0.03} \right] + 100 \left(\frac{166,666 K_{10}}{100} \right) \left[\frac{Q_3}{5000} \right] + 200 \left(\frac{2 \times 10^4 K_{10}}{200} \right) \left[\frac{Q_4}{6 \times 10^3} \right]$$

IF $Q_1 < N_5$

$$\text{SAWGRASS} \left[\frac{\dot{Q}_3}{5000} \right] = \left(2.4 \times 10^6 K_2 \right) \left[\frac{N_3 Q_1 Q_2 Q_3}{1.2 \times 10^{10}} \right] - 10 \left(\frac{K_7}{10} \right) \left[\frac{Q_2}{5000} \right] - K_4 \left[\frac{Q_3}{5000} \right] - K_6 \left[\frac{Q_3}{5000} \right]$$

$$\text{PEAT} \left[\frac{\dot{Q}_4}{6 \times 10^3} \right] = \left(0.83 \times 10^6 K_3 \right) \left[\frac{Q_3}{5000} \right] - \left(K_4 \right) \left[\frac{Q_4}{6 \times 10^3} \right]$$

1c

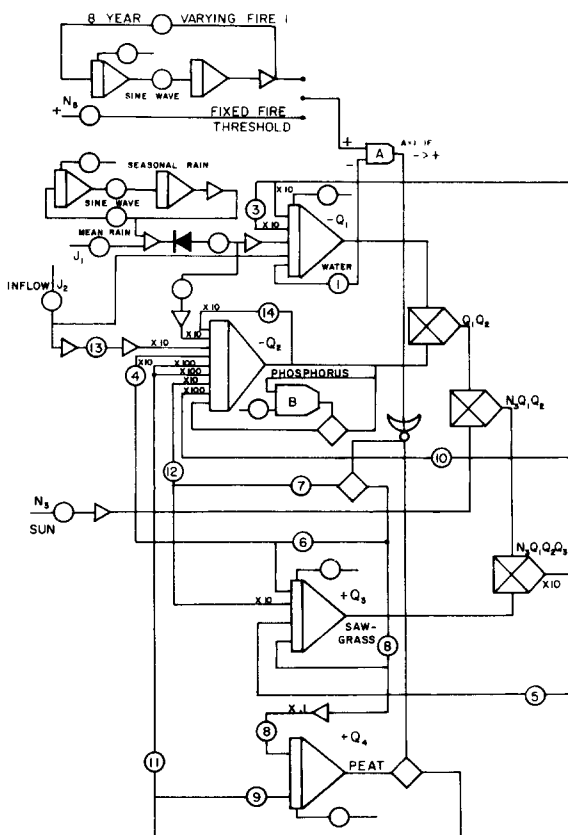

1d

Fig. 1. Model of sawgrass marsh: (1a) using energy circuit symbols; also added are the algebraic terms for each pathway as implied by these symbols; (1b) model written in form of differential equations; (1c) scaled equations for the sawgrass marsh model. Differential equations are scaled so that quantities in brackets are in units of a fraction of the maximum magnitude expected; (1d) analog computer diagram. Numbers in circles are coefficient numbers and the potentiometer number (pots).

for the model are the time lags and depletions which a limiting factor imposes on a system.

These first three compartments respond rapidly to the short term disturbances in the Everglades system. Since peat deposition occurs at a very slow rate (1 foot in 225 years (Davis, 1946)), the peat compartment responds slowly and shows man's effect on the undisturbed system. Other parameters may play an important role in the system (epiphytic algae) and may be included in more complex versions of the model. In this model, emphasis is on those parameters more directly affected by man.

The most important forcing functions are the sun, the rain, sources of flowing water, and the program of fire access. The sun energy was programmed on an average monthly basis. Rain, which occurs in seasonal patterns, was programmed as a sine wave generator. The inflowing water source was that water which is completely controlled by man. In the model, this input can represent Lake Okeechobee water, sewage treatment plant effluent, or the less eutrophic water flow in early times. By varying the value of the coefficient for phosphorus concentration, the water flux and the phosphorus content can be varied independently. Is the sawgrass dependent on inflowing water for an adequate supply of phosphorus in the undisturbed system?

The interrelationship between these parameters in the system control the flows in the model. The standing water storage (Q_1) receives flows from rain and water sources and loses water through transpiration, through evaporation and runoff outside the system. This is shown by the rate equation Q_1 in Fig. 1b. The sawgrass storage receives a photosynthetic flow that is the product of sun, the water, phosphorus and the stock of sawgrass. Together these factors make up the growth coefficient of sawgrass. Each of these individual factors is utilized in the process with a coefficient which will be derived later. Losses from the sawgrass storage include flows for peat deposition, respiration and burning of live sawgrass (equation Q_3 , Fig. 1b).

When nutrient conditions change, ecosystems often change their dominant vegetation. Thus the sawgrass that dominates low nutrient conditions may be displaced by other marsh plants when nutrients are more abundant. The model provides for rise and fall of plant biomass but does not distinguish between species that may be dominant at different times.

The flow from viable sawgrass material to the dead organic pool is very slow, and this is the sole inflow to the peat storage. The outflow is through burning and oxidation. Oxidation of peat normally does not occur until the soil surface is exposed and dry. This occurs in nature after a fire or due to agricultural activities. When this outflow is not utilized, peat accumulates in larger quantities as has occurred over the last 5,000 years in the Everglades.

Phosphorus is regenerated in the system from respiration and by the burning of peat and sawgrass. These three flows and the inputs from rain and flowing water sources determine the amount of phosphorus in the storage (e.g., Q_2 , Fig. 1b). The phosphorus used during growth is taken up at various rates depending on the amount of sawgrass and the amount of water. As

these vary seasonally, phosphorus (P) in the model fluctuates seasonally. It is not known if the real system operates on such a seasonal pattern. The temperature factor was not included in this model.

One of the important considerations that the model attempts to clarify is the role of the inflow water source (N_2) in such marsh systems. In previous times this may have been a very large fluctuating flow into some parts of the Everglades. In the central part of the Everglades National Park, these flows now represent 18 to 60% of the annual water budget. Originally, as much as 1,200,00 acre-feet per year went into the Everglades National Park. At the present time 315,000 acre-feet per year are scheduled, however, lower inflow percentages are scheduled in other areas; higher percentages are maintained in the diked areas for water conservation.

The analog computer model can be run for varying times integrating the interactions of some components with both long and short time constants. The water normally has a large seasonal variation; phosphorus may also have this type of cycle. Fire and sawgrass generally average 8–10 year cycles, while peat accumulated continuously (W. Robertson and R. Miehle, personal communication, 1971). In the Everglades prior to modern man, peat may have burned less frequently than it does now.

Fire is partly controlled by man in the real system. In the model it is indirectly controlled by man by the threshold value on the water level which activates a switch releasing fire energy. Fire may keep the sawgrass system in a state of arrested succession, but this is not known. High water levels may prevent other successional stages (trees) without the effect of fire. The fire may serve to release nutrients and permit a new generation of sawgrass in the same type of burning cycle desirable in some kinds of forest management.

Fire in the model (Fig. 1a) operates with logic switching actions. Two fire pathways releasing phosphorus from peat and sawgrass are turned on when the standing water (Q_1) is at a lower threshold (exerting less force) than the program of fire access (N_5). The fire access is varied as an outside forcing function. The fires start when water is low and may be related to probabilities of fire from thunderstorms and fire setting behavior of man.

Another outside forcing function is a small source of seedling and sprouting (N_4) which is the means for recolonization after fire from those roots and buried seeds that do not burn.

The concentrations of phosphorus in rain and in inflowing water are two of the outside forcing functions which in their interactions are energy forcing functions and shown in Fig. 1a as energy sources. However, these two were held constant during each simulation, although varied in different simulations. Thus, these terms become constants rather than multipliers in the algebraic equations.

Phosphorus tended to surge beyond the scaling limits during fires. A self limiting switch was arranged to flush out phosphorus when its level was in excess of a full scale threshold. Such losses to the air may occur in fires. See comparator B and switch in Fig. 1d.

Nutrients also leave the labile part of the system by being imbedded in deeper peat levels less available to surface processes.

Equations and analog computer program

Another way of writing the model in Fig. 1a is as a system of differential equations given in their simple form in Fig. 1b. The same equations are manipulated algebraically (Fig. 1c) so that each variable is defined by the brackets stays within the voltage range of 100% full scale on the analog computer. Since the denominator of the bracket is the maximum value expected, the fraction within the bracket never exceeds 1 and thus the computer outputs never go off voltage scale of the equipment. The denominator used to keep them on scale is indicated in Table I. These scaled variables (bracketed) were substituted in the equations with algebraic adjustments so that the equality in the equations are retained. Thus their algebraic manipulations are made so that when coefficients are substituted, the setting required on the analog computer will consist of gain factors of ten times the small numbers (between

TABLE I

Estimates of stock and flow, scaling of variables, and initial conditions

Variable	Unit	Average value *	Estimates of maximum value for scaling	Scaled variable **	Initial conditions pot setting
<i>Stock:</i>					
Standing water	mm	300	1,000	$Q_1/1,000$	0.14
Available phosphorus	g/m ²	0.006	0.03	$Q_2/0.03$	0.21
Sawgrass	g/m ²	1,000	5,000	$Q_3/5000$	0.08
Peat	g/m ²	50,000	6×10^5	$Q_4/6 \times 10^5$	0.05
<i>Forcing functions:</i>					
Rain	mm/month	100	1,000	$J_1/1,000$	0.25
Water inflow	mm/month	118	1,000	$J_2/1,000$	0.004
Sunlight		72,000	80,000	$N_3/80,000$	0.9
Source of new growth	g/m ²	—	—	N_4	0.0008
Sine wave for annual water cycle	—	—	—	—	0.524; 0.524
Fire threshold	mm	—	—	$\frac{Q_1 - N_5}{1,000}$	0.07

* Estimated average values used to calculate transfer coefficients

** Variable divided by estimated maximum so the variable will stay on scale of the computer

0.0005 and 0.9999) that can be set with hardware potentiometers (pots).

The resulting scaled equations are given in Fig. 1c from which the analog computer hardware diagram was drawn in Fig. 1d. The analog diagram shows the stepwise movement of wires through which voltage is manipulated to perform the successive mathematical operations of the equations, an item of hardware accomplishing each operation such as addition, subtraction, multiplication, integration, voltage comparison, and switching. This figure is thus a wiring diagram for patching jumper wires on the computer by which the model is operated for whatever coefficients are introduced. Coefficients were computed from data or were quantitative hypotheses. Fig. 1c shows the formula for the pot setting that goes with each numbered pot in the Fig. 1d.

Coefficients

For each pathway of the model there are transfer coefficients (K 's in Fig. 1a) that relate the magnitudes of the flows to the upstream forcing modules. These coefficients are used for both single linear forcing pathways or a multi-

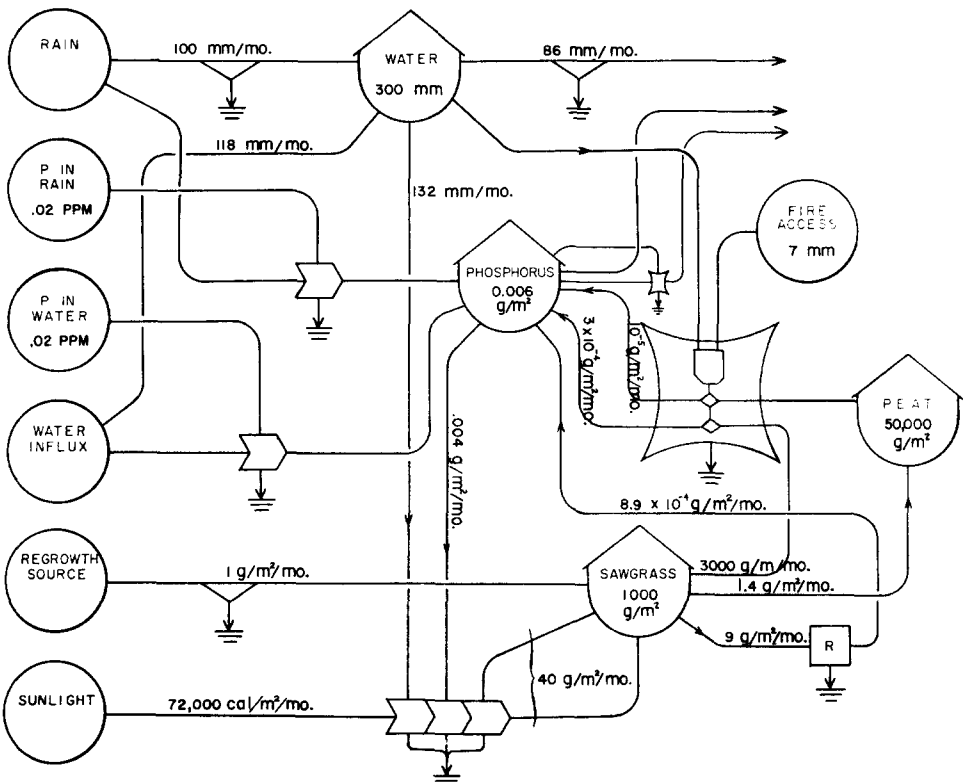

Fig. 2. Estimates of storage stock and flux used to estimate coefficients for the initial simulation.

plier output representing the interaction of several pathways of forcing action. Each coefficient also includes any transformation of measurement units from those of the input forces to that of the output flow. If one knows a value for the pathway's flow and at the same time the values for the storages from which the forces are derived, one may solve the algebraic term for that pathway coefficients as the unknown. As an approximation one may use average values for these quantities if the averages are of the same order of magnitude as those values found occurring in nature.

For example, if the term for the pathway flow of sawgrass to peat is given as $K_8 Q_3$ and the value of the flow is estimated as $1.5 \text{ m}^3/\text{m}^2/\text{month}$ when the gross stock (Q_3) is about $1,000 \text{ g}/\text{m}^2/\text{month}$, K_8 is calculated as $(1.5)/1,000$ or $1.5 \times 10^{-3} \text{ g phosphorus}/\text{l}$.

For the first calculations of coefficients, values of stock and flux were estimated as summarized in Table I and Fig. 2. Then in subsequent simulations some of these numbers were increased or decreased as described in the text and figure legends. Each of these initial numbers is discussed briefly.

Water

The state variable, standing water (Q_1), has an average value of about 300 mm according to F. Nix and J. Davis (personal communication, 1971). Rain-fall contributes an average of 100 mm/month to the storage (Thomas, 1970).

Clayton and Neller (1938) found pan evaporation to be 134 mm/month. Evaporation takes place on bare soil (89 mm/month) for approximately 3 months of the year. Thus evaporation from open water for 9 months and from bare soil for 3 months gives a yearly evaporation rate of 123 mm/month. Evaporation = $K_1 Q_1 = 123 \text{ mm}/\text{month}$.

$$K_1 = \frac{123}{300} = 0.41/\text{month}$$

When evaporation was assumed to be 1/5 of total water input, then $K_1 Q_1 = 45 \text{ mm}/\text{month}$ and $K_1 = 0.15/\text{month}$. This value was used in the second set of simulations.

Clayton and Neller (1938) found evapotranspiration of a sawgrass plot to be 177 mm/month, while that of bare soil was 78 mm/month. The transpiration of the medium dense sawgrass ecosystem is approximately 132 mm/month, or very similar to the value found by Clayton and Neller for pan evaporation (134.6 mm/month).

$$T = 132 \text{ mm}/\text{month} = K_3 N_3 Q_1 Q_2 Q_3$$

$$K_3 = \frac{132 \text{ mm}/\text{month}}{\left(\frac{72,000 \text{ kcal}}{\text{m}^2/\text{month}}\right) (300\text{mm})(0.006 \text{ g}/\text{m}^2)(1,000 \text{ g}/\text{m}^2)}$$

$$K_3 = 1.01 \times 10^{-6} \text{ m}^6 \text{ g}^{-2} \text{ kcal}^{-1}$$

This transpiration was reduced to 60 mm/month when discussions indicated that the previous value was too high. No recent data exist to support either of the values: $T = 60 \text{ mm/month}$; $K_3 = 4.6 \times 10^{-7}$.

Marsh biomass

Davis (1946) found the standing crop of sawgrass (Q_3) to be approximately $1,000 \text{ g/m}^2$ with a life span of 8–10 years. This value then was assumed to be the average standing crop for the storage of sawgrass in the model. The model (Fig. 1) shows the net production of the sawgrass (PP) as proportional to the amount of the water available for transpiration and growth, the amount of available phosphorus, the stock of photosynthesizing plants, and the intensity of sun energy (N_3). These relations can be expressed in the equation $PP = K_5 N_3 Q_1 Q_2 Q_3$. The coefficient, K_5 , in the above expression was derived by substituting the known values for the limiting factors and calculating the only remaining unknown, K_5 .

If the standing crop grows to maturity in 2 years, the net productivity of the sawgrass is:

$$PP = 1,000 \text{ g/m}^2 / 2 \text{ years} = 41 \text{ g/m}^2 / \text{month}$$

$$40 \text{ g/m}^2 / \text{month} = K_5 N_3 Q_1 Q_2 Q_3$$

$$K_5 = \frac{40 \text{ g/m}^2 / \text{month}}{(72,000 \text{ kcal/m}^2 / \text{month})(300 \text{ mm})(0.006 \text{ g/m}^2)(1,000 \text{ g/m}^2)}$$

$$K_5 = 3.1 \times 10^{-7} \text{ m}^3 \text{ 10}^3 \text{ g}^{-1} \text{ kcal}^{-1}$$

The amount of sawgrass lost through respiration can be determined from data given by Davis (1946). If 6/7 of the total sawgrass is respired or oxidized (K_6) and 1/7 deposited into peat, then one can take:

$$6/7 \text{ of } 1,000 \text{ g/m}^2 / 8 \text{ years}$$

$$6/7 \text{ of } 125 \text{ g/m}^2 / \text{year} = 107 \text{ g/m}^2 / \text{year} = 8.9 \text{ g/m}^2 / \text{month}$$

In order to obtain a coefficient for the burning rate of sawgrass, which is an additional loss of sawgrass from the system, it is necessary to know how long it would take to burn the area of interest if fires were present. During numerous fires in Everglades National Park, observations were made on the rate of burning by W. Robertson and R. Miehle (personal communication, 1971). They estimated that it is possible for the entire sawgrass system in the park to burn in 6–10 days. Thus $K_7 Q_3 = \text{total burning of } 1,000 \text{ g/m}^2 \text{ in } 10 \text{ days}$.

$$Q_3 = K_7 Q_3$$

$$\mathcal{T} = \frac{Q_3}{Q_3} = \text{turnover time}$$

$$10 \text{ days} = \frac{1,000 \text{ g/m}^2}{Q_3}$$

$$Q_3 = 100 \text{ g/m}^2/\text{day}$$

$$\frac{Q_3}{Q_3} = \frac{1}{K_7}$$

$$K_7 = \frac{Q_3}{Q_3} = \frac{100 \text{ g/m}^2/\text{day}}{1,000 \text{ g/m}^2}$$

$$K_7 = 0.1 \text{ day} \times 30 \text{ days/month} = 3.0 \text{ month}$$

Peat

Peat storage values were assumed to average $50,000 \text{ g/m}^2$. This is an assigned value and varies in every part of the Everglades. The maximum value of $6 \times 10^5 \text{ g/m}^2$ on 0.610 m peat is also an assigned figure and can go much higher as explained previously. Peat is accumulated especially by deposition of sawgrass. Davis (1946) indicated that $1/7$ of the total plant biomass is turned into peat.

$$\text{Deposition } 1/7 \text{ of } 125 \text{ g/m}^2/\text{year} = 17.86 \text{ g/m}^2/\text{year}$$

$$K_8 Q_3 = 1.5 \text{ g/m}^2/\text{month}$$

$$K_8 = 1.5 \times 10^{-3} \text{ month}$$

Phosphorus

Miller (1918) found that 0.01% of the dry weight of sawgrass is phosphorus. To calculate the phosphorus used in the photosynthesis of sawgrass: the percent dry weight of phosphorus is multiplied by the monthly accumulation of sawgrass. $(0.01\%)(40 \text{ g/m}^2/\text{month}) = 0.004 \text{ g P/m}^2/\text{month}$. This yields the approximate flow of phosphorus required during photosynthesis. The coefficient of proportionality is:

$$0.004 = K_{10} N_3 Q_1 Q_2 Q_3$$

$$K_{10} = \frac{0.004}{1.29 \times 10^8} = 0.0031 \times 10^{-8} \text{ m}^3 10^3 \text{ g}^{-1} \text{ kcal}$$

The monthly respiration $K_6 Q_3$, is $8.9 \text{ g/m}^2/\text{year}$. $K_6 = 0.0089/\text{month}$. Of this 0.01% is phosphorus (Miller, 1918) and is returned to the phosphorus pool. Thus, $K_4 Q_3 = 9.9 \times 10^{-4} \text{ g/m}^2/\text{month}$;

$$K_4 = 8.9 \times 10^{-7}/\text{month}$$

In the model, when water in the storage goes below an assigned value, $Q_1 < N_5$, a switch is activated and the "fire" voltage circuit is completed.

This occurred once every 8 years in one simulation, or every year, depending on the threshold set on the switch.

With the fire switch open, voltage is permitted to flow from the sawgrass and peat storages to the phosphorus storage. Using the value 0.01% of total dry material as phosphorus (Miller, 1918), the generation of phosphorus from burned sawgrass, K_{12} , can be computed.

$$K_7 = 3/\text{month} = \text{amount of sawgrass burned per month}$$

$$K_{12} = (0.0001)(3.0)$$

$$K_{12} = 3.0 \times 10^{-4}/\text{month}$$

Similarly, the amount of phosphorus regenerated from peat was found to be $1 \times 10^{-5}/\text{month}$ ($K_{11} = 1 \times 10^{-5}$) when peat is burned at the rate of 10% per month; $K_9 = 0.1/\text{month}$.

The model is very sensitive to the inflow of phosphorus, especially from rain or eutrophic water. These external sources exert a drastic effect on all integration functions. According to Schneider and Little (1968), rain contains 0.01–0.03 mg/l or approximately 10^{-5} g/l in Florida.

$$K_2 = 10^{-5} \text{ g P/l}$$

$$N_1 = 100 \text{ mm/month} = 10^2 \text{ l/m}^2/\text{month}$$

$$K_2 N_1 = (10^{-5} \text{ g P/l})(10^2 \text{ l/m}^2/\text{month})$$

$$K_2 N_1 = 0.001 \text{ g P/m}^2/\text{month}$$

Inflow of external sources of water supplies an estimated 1 mg/l of total phosphorus. This can be varied at will. $K_{13} = 10^{-3}$ mg P/l. The phosphorus storage has been assigned an average storage of 0.02 mg/l total phosphorus from a recent report (Sullivan et al., 1971). $Q_2 = 0.02$ mg/l P or 0.006 g/m². The maximum value observed entering the Everglades National Park in the dry season was 0.05 mg/l. Since no data are available on phosphorus in the sawgrass system itself, maximum values were assigned. Q_2 (max.) = 0.1 mg/l = 0.03 g/m².

SIMULATION RESULTS

In an attempt to imitate the erratic pattern of marsh fires in the Florida Everglades, in the model the nutrient content of the inflowing water was first increased beyond the historical concentrations. This produced the typical simulation in Fig. 3. During the first year as the water rose in its yearly cycle, some of it was taken up and transpired by the grass, until continued rain and runoff water brought the water levels up to the yearly maximum. Sawgrass built up biomass rapidly to the yearly maximum and then cycled slightly due to respiration and diminished photosynthesis during the dry season. Phosphorus was taken up rapidly by the sawgrass and external levels

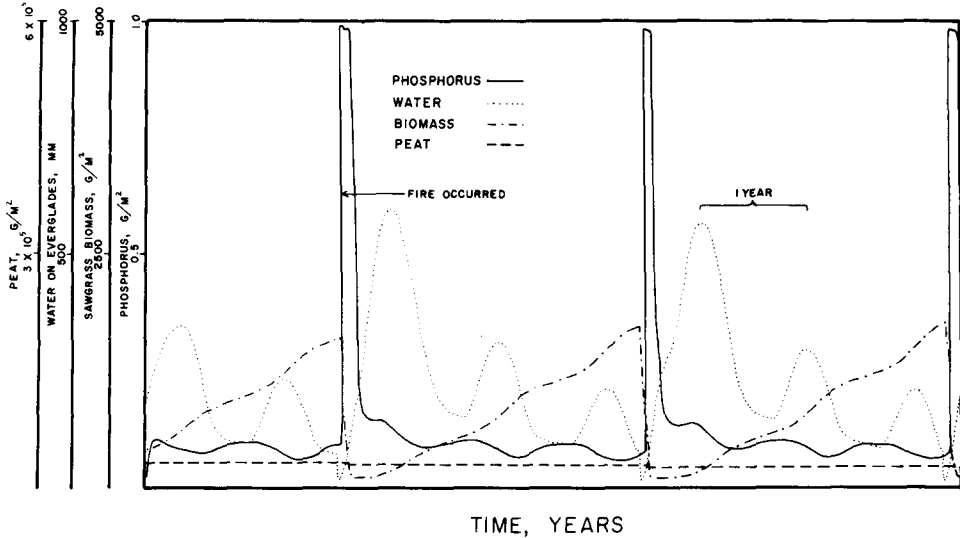

Fig. 3. Sawgrass system with high inflow water and high phosphorus concentrations. Pot settings: inflow water 0.1763 (176 mm/month); phosphorus in the following water 0.0332 (0.099 mg/l).

declined to very low levels. In the second year as the yearly rains and runoff brought water into the system, sawgrass built up to an even larger system standing crop. In doing so the water levels dropped below a fixed reference point whereby fire occurred. The fire caused the grass to burn and release some portion of the burned products into the phosphorus pool making it available for new growth.

The pattern of fires in the original Everglades may have been less frequent. The simulation in Fig. 4 may approximate the original Everglades, with sawgrass, water levels and phosphorus concentrations fluctuating on an annually undulating sinusoidal pattern. Since in this simulation fire was programmed to occur when water levels decreased to 7 mm in the water storage, no fires developed. The water levels oscillated regularly from 325 mm to 575 mm. The sawgrass biomass reached approximately 920 g/m². In this simulation low inflow phosphorus (0.0012 mg/l) and a moderate volume of inflow water, 118 mm/month (such as water from Lake Okeechobee flowing south) were used as the forcing function. Most of the available phosphorus originated in the rain.

When inflow phosphorus concentrations were increased to 0.027 mg/l phosphorus and the Lake Okeechobee water remained the same (118 mm/month); the model took on the typical simulation behavior (Fig. 5). Sawgrass growth increased to very high levels in the storage (1,850 g/m²), dropped to zero when burned, built up rapidly to 400 g/m², but again burned in a series of small fires. Water levels remained very low, even though

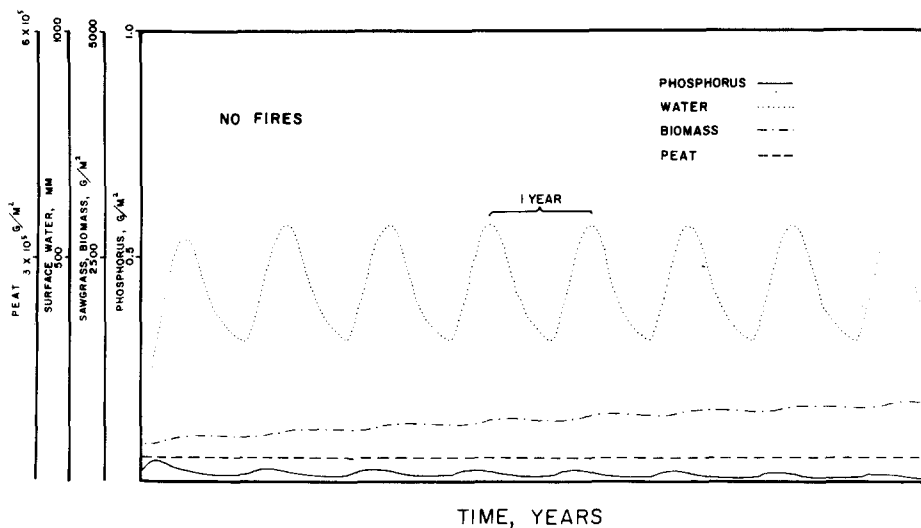

Fig. 4. Sawgrass system with moderate inflow water and low phosphorus concentration possibly similar to the Original Everglades. Pot settings: inflow water 0.1185 (118.5 mm/month); phosphorus in inflow water 0.0004 (0.0012 mg/l).

little sawgrass was present. Fig. 3 where both phosphorus and inflowing water were set at slightly higher levels (0.1 mg/l and 176 mm/month respectively) differed dramatically. Sawgrass increased to approximately 1,500 g/m² in 2 years, while the water decreased from 350 mm to 235 mm and then decreased to 7 mm whereby fire occurred. However, after the fire the water levels rose quickly to 590 mm decreasing again as sawgrass grew. This interaction of only two parameters producing widely differing effects on the system makes prediction difficult.

When the phosphorus inflow was programmed to occur at the concentrations measured in Lake Okeechobee water and the primary phosphorus to the system came in the rain, the available phosphorus oscillated with a sinusoidal pattern in phase with the water level. Fig. 3 and 5 show that as phosphorus in Lake Okeechobee increased, the available phosphorus oscillated at higher levels and out of phase with the water level, until fire occurred whereupon it goes to the maximum level. As sawgrass growth occurred, phosphorus was utilized when water was available and the levels lowered. This resulted in oscillations which were out of the phase with the water levels and incoming phosphorus.

The effect of water and fire on the peat storage was more predictable. When additional water was added to the system and no fires occurred, peat accumulated (Fig. 4). When a fire did occur, the accumulation was gradually reduced to zero (Fig. 5). Small amounts of additional water, permitting regular fires, produced a pattern where peat burned each year at the same time with various quantities of the material being destroyed. When no water was

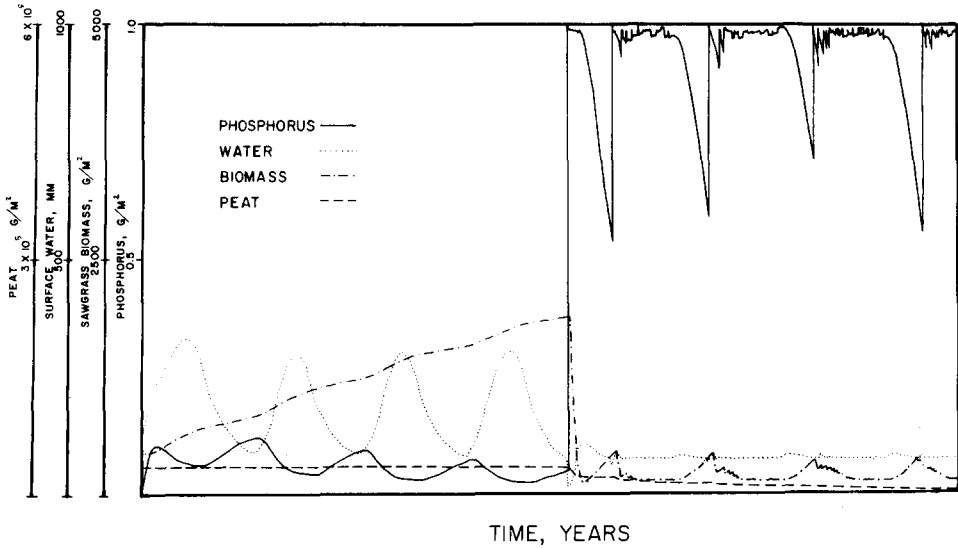

Fig. 5. Sawgrass system with moderate inflow water and moderate phosphorus concentrations. Pot settings: inflow water 0.1185 (118 mm/month); phosphorus in inflow water 0.0089 (0.027 mg/l).

added, the peat burned immediately with no accumulation remaining. There was no increase in the peat because no sawgrass remained in the system.

A second set of simulations was run with water being transpired by the marsh at a lower rate (60 mm/month vs 132 mm/month). The only data available showed high transpiration for sawgrass in the artificial tanks, but this may be atypical of the natural marsh situation. Fig. 6 approximates the original Everglades with a low (0.0012 mg/l) phosphorus inflow. However, this also has a low (5 mm/month) Lake Okeechobee inflow. Comparison with Fig. 4 with a high transpiration rate shows that with even less inflow water coming in, the sawgrass levels in Fig. 6 build up to a higher level. The water levels fluctuated with a greater amplitude with the low transpiration control and the maximum value was only slightly lower even though 113 mm/month less water entered the system. In Fig. 7 the phosphorus inflow values were high (0.31 mg/l), but the water remained at low levels (5 mm/month) similar to the real situation during part of the 1960's. Here the sawgrass burned every year.

In the next simulations, access to fire (N_5) was programmed using a second sine wave generator (Fig. 1d) arranged to produce fire when one sine wave coincided with the other. At this time water level (Q_1) was low and fire setting (N_5) was high. This arrangement permitted low water levels to occur without the necessity of a fire.

In Fig. 8 the sawgrass population built up to the maximum permitted since the fire access was not on. This simulation received moderate inflow

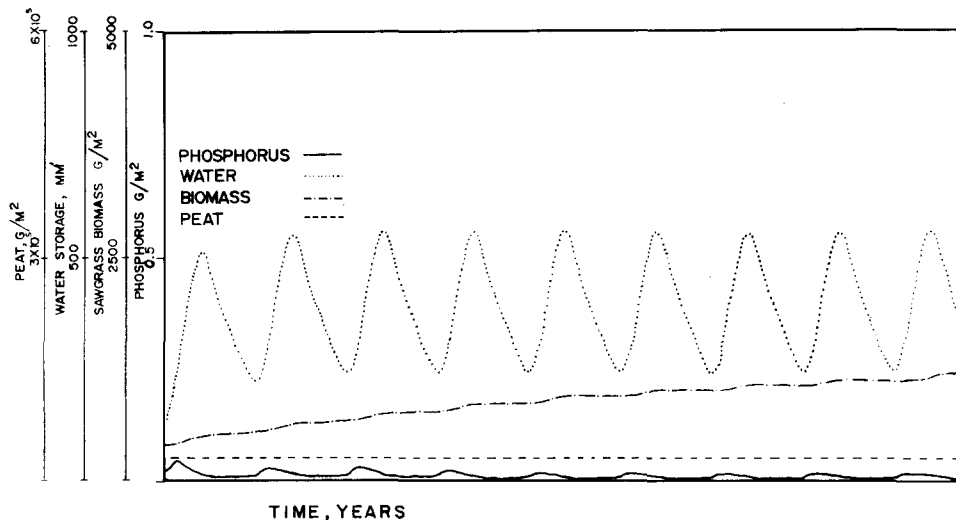

Fig. 6. Original Everglades Model using low transpiration value. Inflow water (5 mm/month); inflow phosphorus (0.0012 mg/l).

phosphorus (0.08 mg/l) and moderate inflow water (118 mm/month). Comparison with Fig. 9 which had 0.37 mg/l of phosphorus and 140 mm/month of water but a high transpiration rate shows the sensitivity of the model to the various parameters: water level, inflowing phosphorus and transpiration. With the high transpiration rate the sawgrass biomass reached 3,000 g/m²

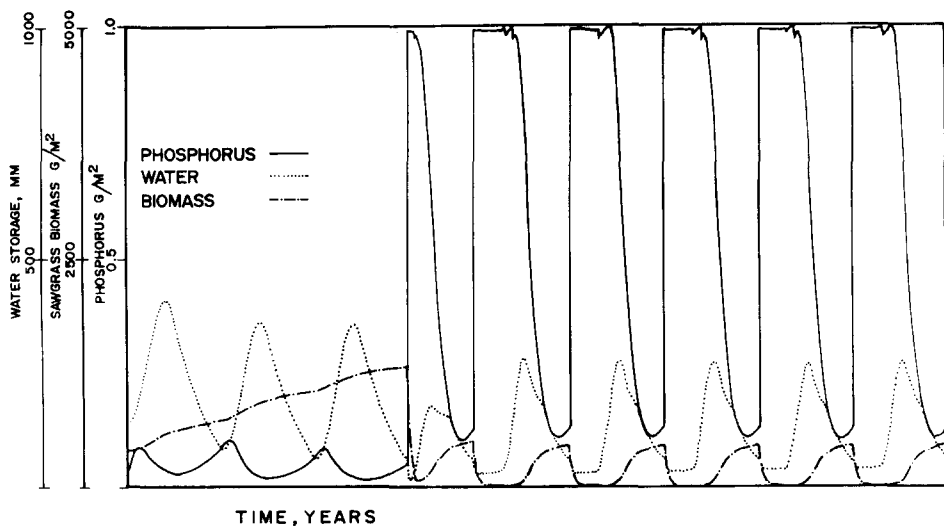

Fig. 7. Sawgrass Model with a low transpiration value. High inflow phosphorus values (31 mg/l) and low inflow water (5 mm/month) were used.

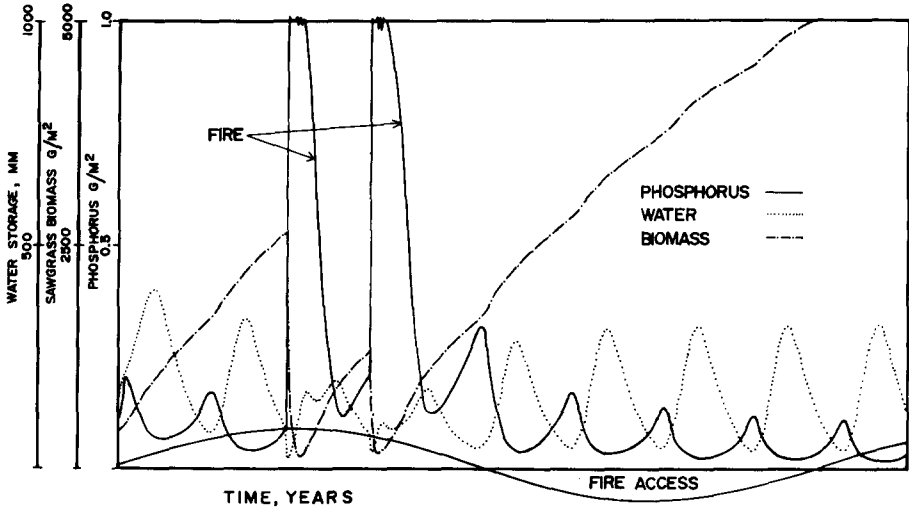

Fig. 8. Sawgrass Model with a low transpiration value and a sine wave fire program. Moderate inflow water (118 mm/month) and moderate inflow phosphorus (0.08 mg/l) were used.

and the water was reduced to very low levels. In Fig. 8 the water levels continued to fluctuate yearly from 50 mm/month to 300 mm/month since using the low transpiration rates, water and phosphorus were not limiting nor drastically pulled down by the transpiration of the sawgrass.

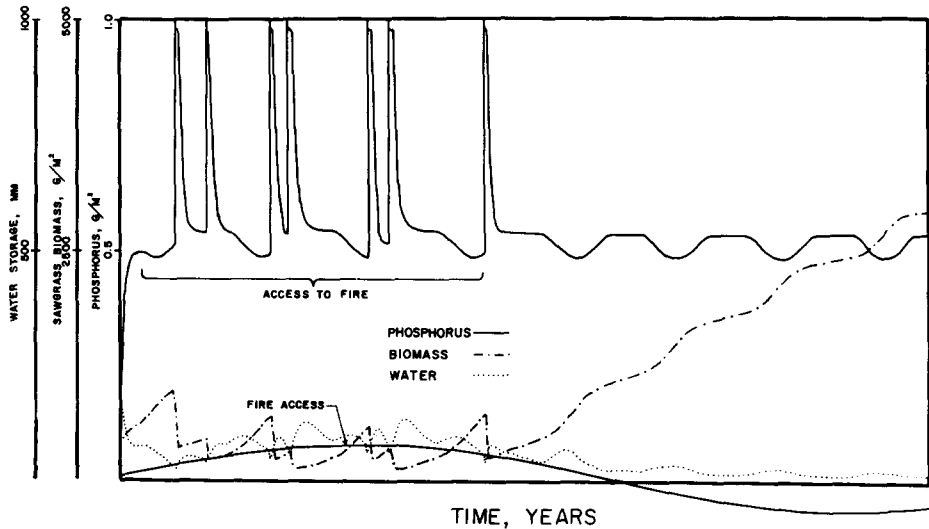

Fig. 9. Sawgrass system with a high transpiration value on a sine wave fire program with high inflow of water and high phosphorus concentration. Pot setting: inflow of water 0.1407 (140 mm/month); phosphorus in inflow water 0.1239 (0.37 mg/l); rain 0.0993.

DISCUSSION

Some of the properties of the simulations were due to certain assumptions incorporated into the model. If water and phosphorus uptake are taken to be simple linear functions of the amount of photosynthesizing sawgrass, then the amount of water on the surface depends not only on the rain but on the amount of transpiration and hence, on the amount of sawgrass. Although few studies have considered the effect of nutrient action on the transpiration and thus on the water levels, it may be an exaggeration to make the vegetation a primary controller of water level. Data on transpiration for various vegetation conditions is urgently needed.

There is tentative hydrologic data indicating that indeed the vegetation does manage the hydroperiod. In many areas of Florida, trees, especially eucalyptus trees, are planted in wet areas to dry out the soil. So although these assumptions were incorporated into the model, there does seem to be some justification from empirical data now being gathered. In any case, the dramatic effect that these assumptions have in the model show the urgency for accurate research on transpiration and on the effect of vegetation on the regional water budget before land use changes drastically alter the landscape, and inadvertently disrupt the water budget on which all of south Florida is dependent.

This model indicated the sensitivity and unpredictability of a rather simple ecosystem which is currently being drastically altered in Florida, especially by lowered water tables and changed hydroperiods. It also identifies data needed to evaluate this ecosystem. Very small changes in phosphorus and overland water flow in the model produce radical changes in the system and make prediction impossible. The sensitivity of the water inflow may be due partly to its effect on a limiting nutrient or partly by directly affecting the amount of water available for photosynthesis and to control fire. The sensitivity of the phosphorus flow or any limiting nutrient may be in its ability to permit growth and therefore provide biomass to be burned. At some combinations of phosphorus and water inflow, the simulations indicate that pollution can cause fires and accelerate water loss.

Slight differences in the way fire was programmed in the model have dramatic effects on the system. Prevention of fire for long periods in the model results in larger fires. This could be similar to forestry policy in many parts of the country that are only gradually changing. In the Everglades attempts are still made to control fires. In addition, water inflow from the north and nutrient levels are manipulated by agricultural and governmental practices. Thus from this model one would expect a frequent and erratic fire situation to occur in the Everglades of south Florida.

REFERENCES

- Clayton, B.S. and Neller, J.R., 1938. Water Control Investigations. Univ. Fla. Agric. Exp. St., Annual Report.

- Clayton, B.S., Neller, J.R. and Allison, R.V., 1938. Water Control in the Peat and Muck Soils of the Florida Everglades. Univ. Fla. Agric. Exp. St. Bull. No. 378.
- Davis Jr, J.H., 1943. The Natural Features of Southern Florida, Especially the Vegetation and the Everglades. Fla. Geol. Survey, Geol. Bull. No. 25.
- Davis Jr, J.H., 1946. The Peat Deposits of Florida. Fla. Geol. Survey, Geol. Bull. No. 30, 247 pp.
- Johnson, L., 1958. A Study of the Water Resources of Everglades National Park. Florida Consulting Engineers. Report to Central and South Florida, Flood Control District, West Palm Beach, Fla.
- Loveless, C.M., 1959. A study of the vegetation of the Florida Everglades. *Ecology*, 40: 1-9.
- McPherson, B.F., 1971. Water Quality at the Dade-Collier Training and Transition Airport, Miami International Airport, and Cottonmouth Camp — Everglades National Park. U.S. Geological Survey, Open File Report 70011.
- Miller, C.R., 1918. Inorganic composition of a peat and of the plant from which it was formed. *J. Agric. Res.*, 13 (12): 605-609.
- Schneider, R.F. and Little, J.A., 1968. Characterization of Bottom Sediments and Selected Nitrogen and Phosphorus Sources in Lake Apopka, Florida. USDI Fed. Water Pollut. Control Adm., S.E. Water Lab., Athens, Ga., 42 pp., mimeographed.
- Stephens, J.C., 1956. Subsidence of organic soil in the Florida Everglades. *Soil Sc. Am. Proc.*, 20: 77-80.
- Sullivan, J.H., Fox, J.L., Furman, T.D., Lackey, J.B., Singley, J.E. and Patterson, A.O., 1971. Water Quality Study — Everglades National Park. Water Air Res., Inc., Gainesville, Fla., 59 pp.
- Tabb, D., 1963. A Summary of Existing Information on the Freshwater, Brackish Water and Marine Ecology of the Florida Everglades Region in Relation to Freshwater Needs of the Everglades National Park. *Inst. Mar. Sci.*, Univ. Miami, Coral Gables, Fla., mimeographed.
- Thomas, T.M., 1970. A Detailed Analysis of Climatological Records of South Florida with Reference to Man's Influence upon Ecosystem Evolution. Rosenstiel School of Marine and Atmospheric Science, Report to the U.S. National Park Service 70-2, Univ. Miami, Miami, Fla.